



BIG FOOT SYSTEM GENERAL ASSEMBLY GUIDELINES

BBJ ENGINEERING LTD

1 Take the LEG BRACKETS from each of the Big Foot LEG ASSEMBLIES.

2 Lay out the PLAIN BARS, CROSS BARS, LEG BRACKETS and STRAIGHT CONNECTORS (if needed), so you can check the position of everything.

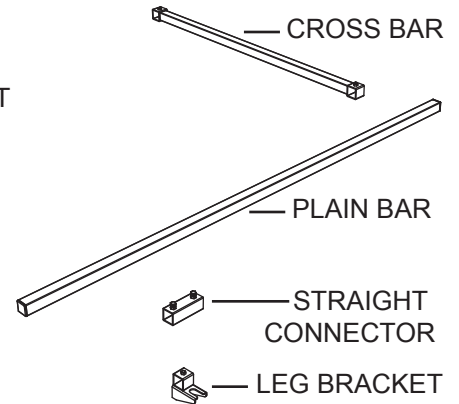
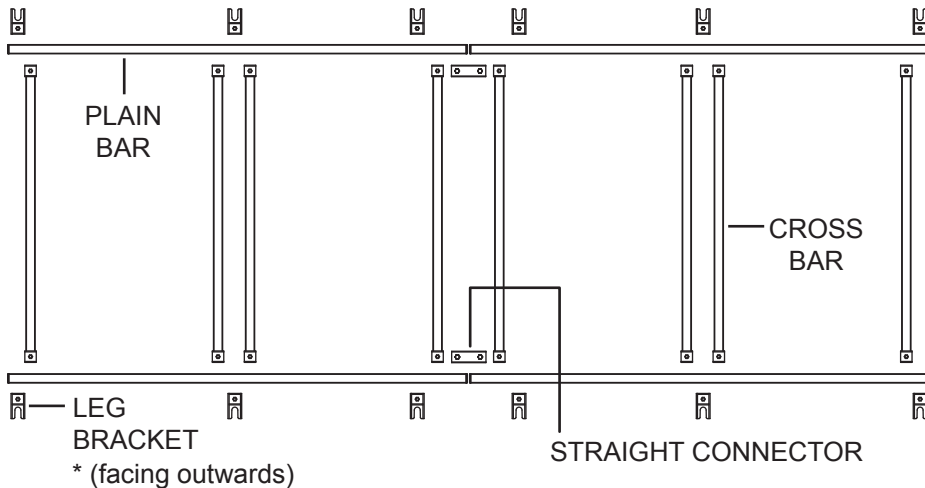

3 Double check the spacing of the CROSS BARS against the condensers, to ensure the support will be in the right place.

4 * Note: LEG BRACKETS will normally face outwards, so the LEG ASSEMBLY is outside the framework. However, if the framework is in a limited or partially limited space, some LEG ASSEMBLIES may need to be located inside the framework. In these situations, ensure the LEG BRACKETS face inwards.

5 Leaving the components laid out in the required position, assemble one section at a time, by sliding the two PLAIN BARS through the CROSS BARS and LEG BRACKETS:

6 Semi-tighten the bolts on the CROSS BARS and LEG BRACKETS.

7 Lift each section and fit the LEG ASSEMBLIES onto the LEG BRACKETS. Adjust the height of the fixings on the LEG ASSEMBLIES as required and tighten:

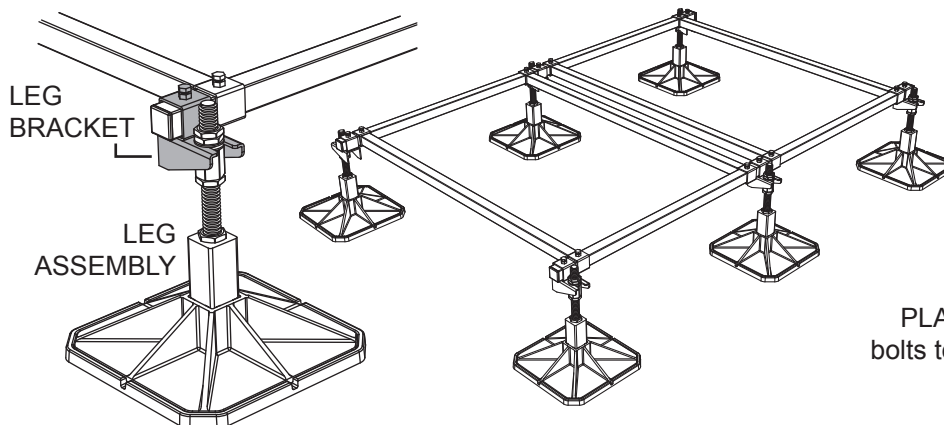
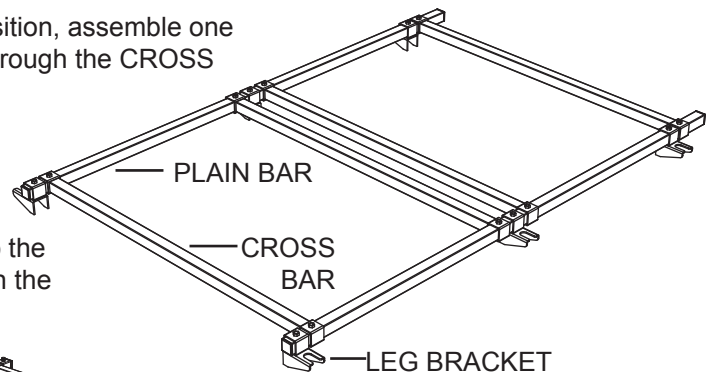

8

If the Big Foot System has more than one section, fit the STRAIGHT CONNECTORS onto the ends of the PLAIN BARS to join the sections, tighten bolts to secure the two joined PLAIN BARS:

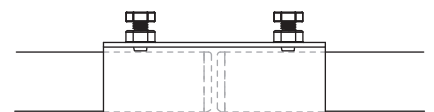

9 Tighten the entire framework and position condenser units on CROSS BARS.

10 If suitable, use the CLAMPS provided to secure

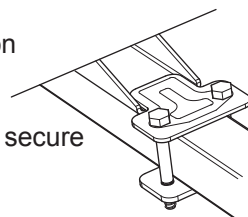

condensers units onto the CROSS BARS.

08/2006